

PRESSURE TANKS FIXED MEMBRANE TYPE

For storage of water under pressure

APPLICATION

For storage of water under pressure, pressurisation systems pressure booster sets and wet tank replacement

DESIGN FEATURES

- Tank deep drawn steel shell for extra strength with epoxy enamel paint
- Fixed membrane diaphragm
 - Never stretches or creases
 - No bubbles or corners to trap sediment
- Patented geometric design for 80 litre tanks



TECHNICAL DATA

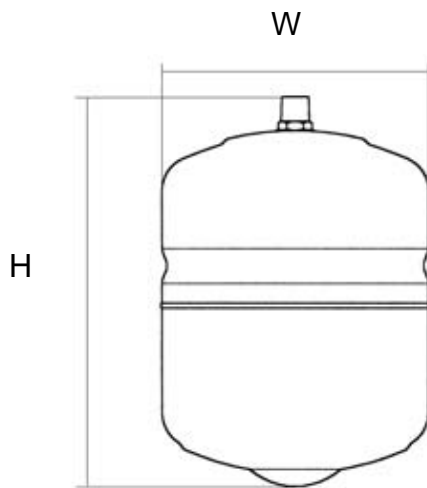

DT8/24

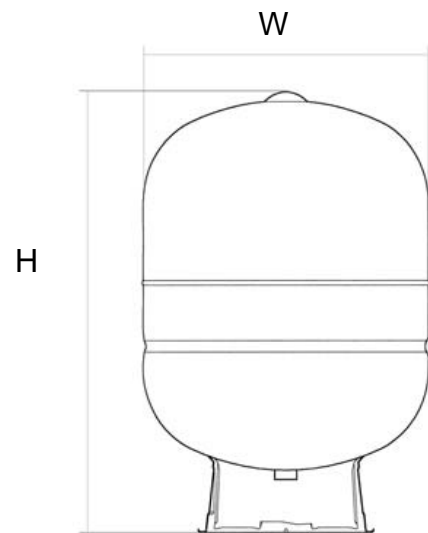

DT50/80

Part No	Capacity	Connection	Air Pre-Charge	Max Working Pressure
DT8	8 Litres	20mm BSPm	300kPa	1000kPa
DT24	24 Litres	25mm BSPm	300kPa	1000kPa
DT50	50 Litres	25mm BSPm	300kPa	1000kPa
DT80	80 Litres	25mm BSPm	300kPa	1000kPa

Part No	Physical Dimension	Packaged Dimension
DT8	W 205mm x H 300mm	210mm x 210mm x 320mm
DT24	W 320mm x H 355mm	330mm x 330mm x 375mm
DT50	W 400mm x H 585mm	410mm x 410mm x 610mm
DT80	W 400mm x H 820mm	410mm x 410mm x 860mm